

## Concentration gradients inside $\mu$ -Slide I

The microfluidic channel of the  **$\mu$ -Slide I** is suited to set up chemical gradients. By a simple pipetting procedure a concentration profile can be established. The profile is well known and has been shown to stimulate chemotaxis in fast migrating cells such as *Dictyostelium discoideum*.

In contrast, for chemotaxis experiments of slow migrating cells we recommend our  $\mu$ -Slide Chemotaxis (*80301-hydrophobic, uncoated* or *80302-Collagen IV coated*).

### Short recipe

- Seed cells into  $\mu$ -Slide I and wait until cells have fully attached. See step "**1. Seeding cells**".
- Establish the gradient following step "**2. Pipetting procedure**".
- Find the steepest point of the gradient following procedure "**4. Determination of observation area**".
- Analyze cell movement by time-lapse microscopy.

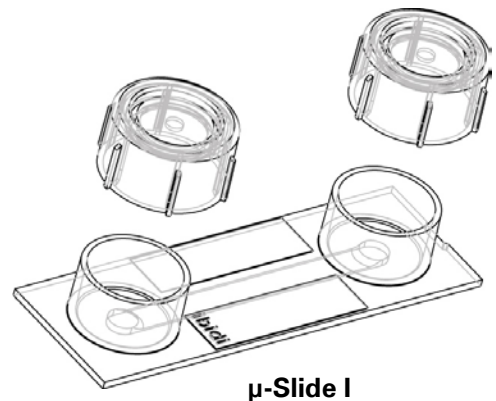

### 1. Seeding cells

- Prepare cells as usual and fill 100  $\mu$ l of the cell suspension into the channel (see **Fig. 1 A**). We recommend  $3-7 \times 10^5$  cells/ml.
- Cover reservoirs loosely with the supplied caps. Await cell attachment.
- For longer cultivation fill each reservoir with 600  $\mu$ l cell-free medium.
- For more details on cell seeding see the instructions for  $\mu$ -Slide I or visit [www.ibidi.com](http://www.ibidi.com).

### 2. Pipetting procedure for gradient

To set up the concentration profile you only need a standard laboratory pipette and your chemoattractant solution.

- Empty the reservoirs if necessary. Leave the channel filled with 100  $\mu$ l of medium (without attractant).
- Apply 20 - 40  $\mu$ l of your chemoattractant in one reservoir (see **Fig. 1 B**)
- Aspirate the same amount of liquid (20 - 40  $\mu$ l) from the opposite reservoir (see **Fig. 1 C**).
- Cover reservoirs loosely with supplied lids

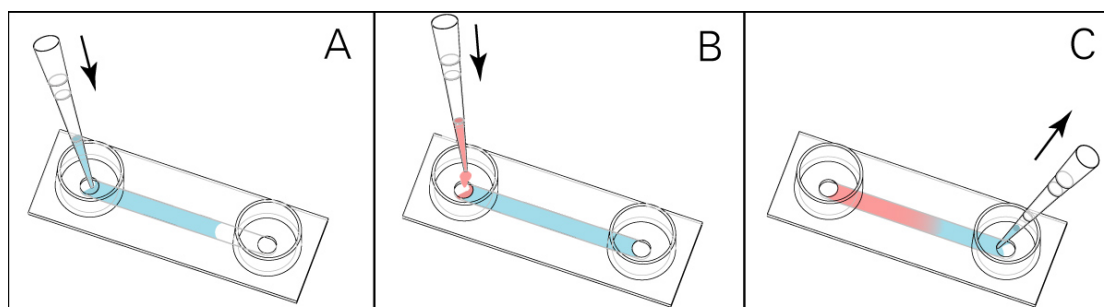

**Fig. 1 Pipetting the gradient**

## Application Note 01



Fig. 2: Image of green colour gradient.

### 3. Concentration profile

Measurements with the fluorescent dye Rhodamine 6G showed that the distribution of chemoattractant is half-parabola shaped (solutions 10  $\mu\text{M}$  and 100  $\mu\text{M}$ , 40  $\mu\text{l}$  Rhodamine as chemoattractant).

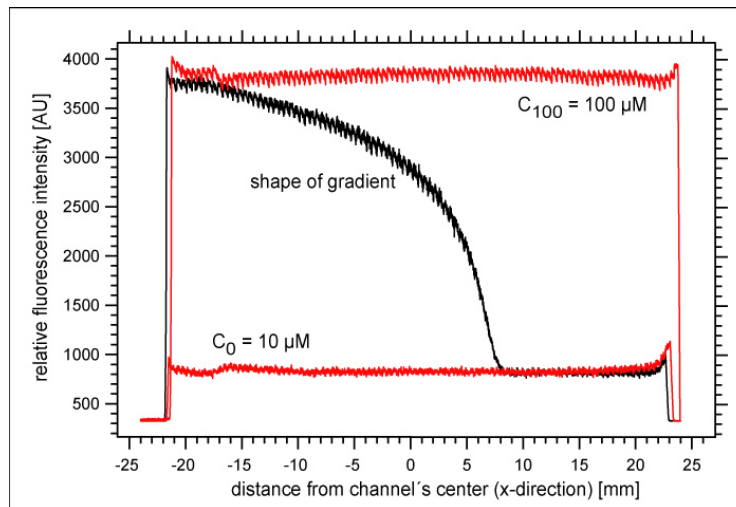

Fig. 3: Concentration profile measured with a fluorescence dye. The fluorescence intensity is plotted versus the distance in x direction. The two references  $C_0$  and  $C_{100}$  were measured in separate channels

The shape of the concentration profile indicates that the profile is originated in the characteristic flow profile between two parallel plates. Measurements were taken 10  $\mu\text{m}$  above the cells using confocal techniques. 40  $\mu\text{l}$  of chemoattractant solution was used. Different volumes result in similar shapes.

### 4. Determination of observation area

Responses of cells depend on the area of observation. Using beads it is possible to visualize the chemoattractant gradient. We recommend the following procedure:

- Small microscopy beads of any kind can be used. We suggest e.g. for FITC filter sets fluorescent beads from Molecular Probes, (FluoSpheres®, 10  $\mu\text{m}$  F8836). Please check for your desired fluorescence wavelength or use phase contrast microscopy.
- Recommended concentration of beads:  $5 \times 10^6$  beads/ml.
- Add the beads directly to your chemoattractant solution and follow the pipetting procedure as described in **2**.
- Find the position of the bead which is rinsed farthest into the channel. For 40  $\mu\text{l}$  chemoattractant solution the expected position is about 7-9 mm from the center of the channel (or 30 mm from the channel's aperture).

## Application Note 01

The steepest gradients can be found in a region near  $x_{\max}$ . This area is at least 1.5 mm wide. To visualize the concentration profile while using cells we recommend the use of fluorescent beads to determine where the cells should be observed.

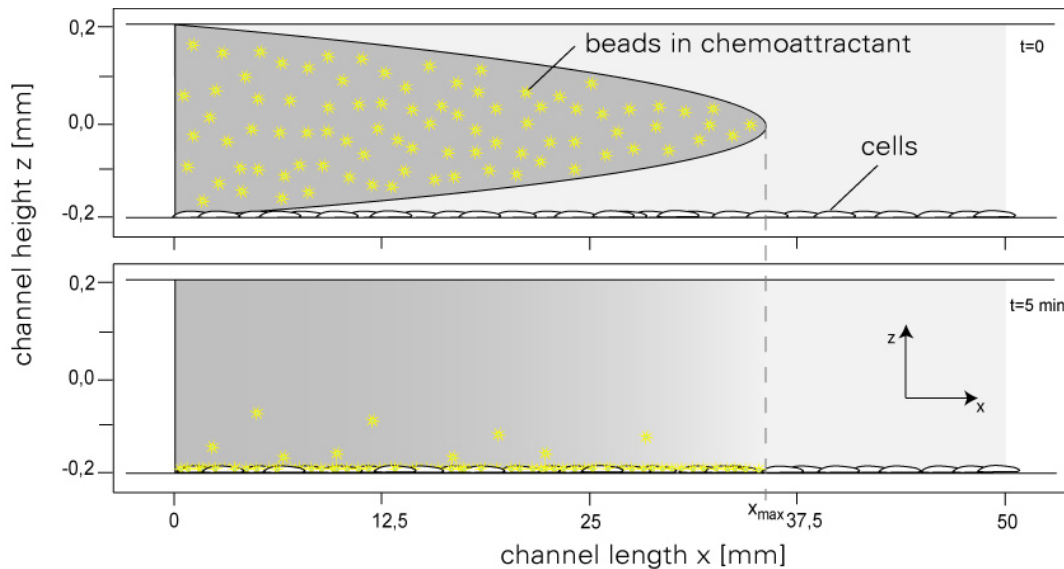

**Fig. 4** After flushing chemoattractant and beads into the channel a stretched parabola-like shaped form is created. After some minutes the gradient is established and beads fall down showing the area of interest.

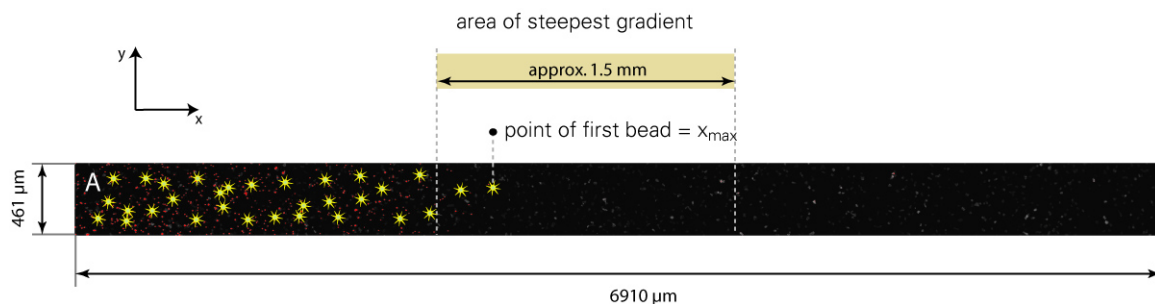

**Fig. 5** The steepest gradient area is defined by the first bead inside the attractant solution.

### 5. Range of the pipetted chemoattractant

For different volumes of chemoattractant the approximate position of the steepest gradient  $x_{\max}$  of the pipetted chemoattractant can be calculated:

$x_{\max}$  is the position measured from the channel aperture, which is used for filling in the chemoattractant.

$$x_{\max} = \frac{3}{2} \cdot \frac{V}{h \cdot w}$$

$V$  is the pipetted volume,  $h$  is the height, and  $w$  is the width of the fluidic channel. With the given geometries inside the  $\mu$ -Slide I we get for 40  $\mu$ l attractant solution:

$$x_{\max} = \frac{3}{2} \cdot \frac{40 \text{ mm}^3}{0,4 \text{ mm} \cdot 5 \text{ mm}} = 30 \text{ mm}$$

## Application Note 01

Due to interfering edge effects we determined the reproducibility of the pipetting procedure as  $\pm 1$  mm. Therefore, we recommend the use of beads to exactly localize the observation area.

### 6. Time development of the concentration profile

Dependent on diffusing chemoattractant, viscosity, and temperature the gradient will be blurred after some time.

Small chemoattractant molecules (e.g. cAMP):

The observation time starts immediately after the pipetting procedure. Small molecules will form a proper gradient for single cell applications for approx. 30-60 min.

Large chemoattractant molecules (e.g. VEGF):

The observation time starts immediately after the pipetting procedure. The gradient is steep enough for single cell chemotaxis for approx. 0.5-2 hrs.

Although the gradient is visible for much longer time it is strongly dependent on the experiment whether the gradient is steep enough for single cell chemotaxis. Thus, experiments dealing with different concentrations on different positions in one channel are possible for much longer times.

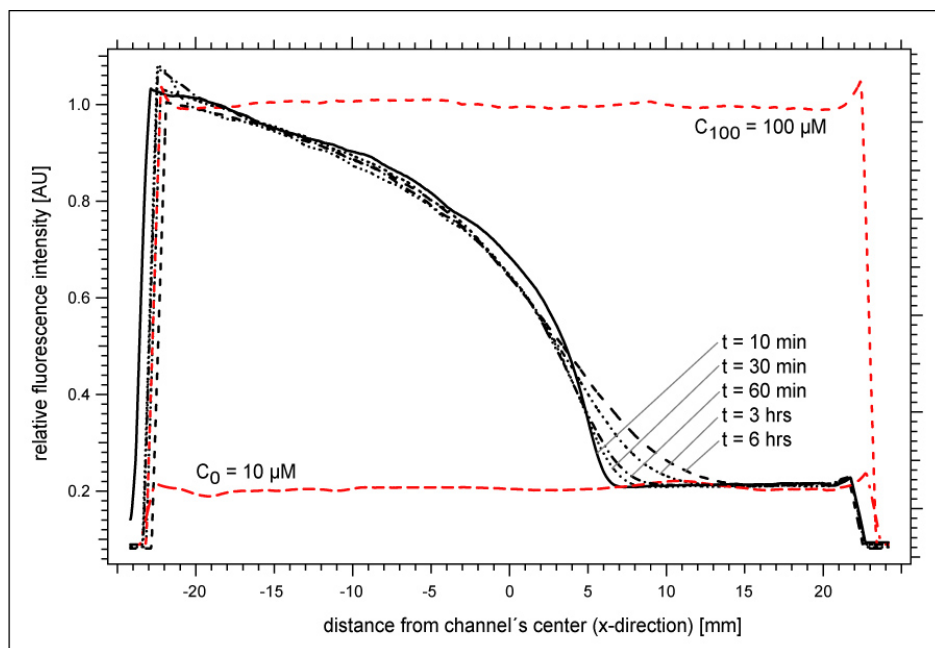

**Fig. 6 The pipetted gradient flattens over time.**

For more time stable gradients we recommend our  $\mu$ -Slide Chemotaxis which provides much longer gradient stability (more than 48 hrs). It is designed for slow migrating cells.

Please contact us for further information. ([info@ibidi.com](mailto:info@ibidi.com))