

3D Chemotaxis Assays Using μ -Slide Chemotaxis^{3D}

0 Important Notes

- Read the related document “Important Notes” first.
- Follow all of the steps in this Application Note carefully.
- Start by using the free samples and the food coloring, which are included.
- Read through the detailed information in the “Notes” section, at the end of this document.



Table of Contents





0	Important Notes	1
1	General Information.....	2
2	Principle.....	2
2.1	3D Chemotaxis Experiments in Gel Matrices.....	3
2.2	2D Chemotaxis Experiments Without Gel.....	3
3	Equipment.....	4
4	Surfaces and Coatings.....	4
4.1	ibiTreat (80326).....	4
4.2	Collagen IV Surface Coated (80322)	4
5	3D Experiment with Cells in Gel.....	5
5.1	Seeding Cells in Gel	5
5.2	Filling the Reservoirs	6
5.2.1	Fast Method.....	6
5.2.2	Slow Method.....	7
6	2D Experiment with Cells on a 2D Surface	8
6.1	Seeding Cells.....	8
6.2	Cell Attachment.....	9
6.3	Filling the Reservoirs	10
7	Video Microscopy.....	11
8	Chemoattractant Concentrations and Recommended Experimental Setups	12
9	Tracking Cells as a 2D Projection	12
10	Analyzing Chemotaxis	14
11	Tips, Tricks, and Troubleshooting.....	15
11.1	Avoiding Air Bubbles	15
11.2	Focus Not Stable	16
11.3	Chamber Not Filling Properly.....	16
11.4	Cells Die in the Gel Matrix.....	16
11.5	Cells Do Not Migrate in Gel.....	16
11.6	Cells Do Not Attach Properly (2D Assay Only)	17
11.7	Inhomogeneous Cell Distribution (2D Assay Only).....	17
12	Notes.....	17
12.1	Note: Gel Filling.....	17
12.2	Note: Cell Morphology	17
12.3	Note: Cell Tracking	17

Application Note 17

1 General Information

μ -Slide Chemotaxis^{3D} is a tool used for observing the chemotactical responses of cells being embedded in a 3D gel matrix, and exposed to chemical gradients.

Color code for liquids in this Application Note:

-  Cells suspended in gel
-  Cell-free medium without chemoattractant
-  Chemoattractant
-  Cell suspension without gel

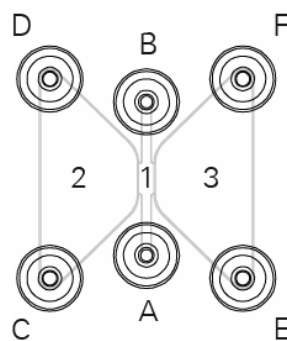
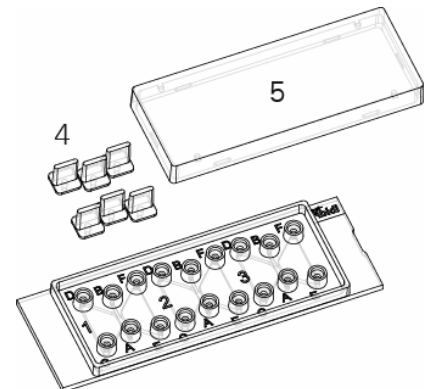

Chamber configuration:

- 1) Observation area (1000x2000 μm^2)
- 2) Left reservoir (60 μl)
- 3) Right reservoir (60 μl)
- 4) Plugs
- 5) Cultivation lid
- A) Filling Port A (with side channel)
- B) Filling Port B (with side channel)
- C) Filling Port C (left side)
- D) Filling Port D (left side)
- E) Filling Port E (right side)
- F) Filling Port F (right side)

2 Principle

Two large-volume reservoirs are connected by a small gap. If the large reservoirs contain different chemoattractant concentrations (indicated in this document by the red and blue colors), then there is a linear concentration drop inside this gap. Cells that are placed into this gap (=observation area) are exposed to linear concentration gradients. In steady state, there is a homogeneous concentration inside the large reservoirs.



Application Note 17

2.1 3D Chemotaxis Experiments in Gel Matrices

When conducting 3D experiments, the observation area is filled with cells that are surrounded by a gel. This gel hinders the convective flow of liquid, so that both large reservoirs can be filled directly and completely with C_{100} and C_0 solutions (see 5.2.1 Fast method, on page 6). Alternatively, both reservoirs can be filled with C_0 first. Later, C_{100} (using double concentration) can be added with a special method (see 5.2.2 Slow method, on page 7). The latter, more complicated method, avoids initial contact between the chemoattractant and cells in the gel. This can be advantageous when cells are susceptible to being blocked by a chemoattractant, before the system undergoes steady state.

Typical aqueous gels (like collagen gels) are not thought to hinder diffusion. When using stiff hydrogels with pore sizes, in the range of the diffusing molecules, this approach is invalid and no chemical gradient can be established inside the gel.

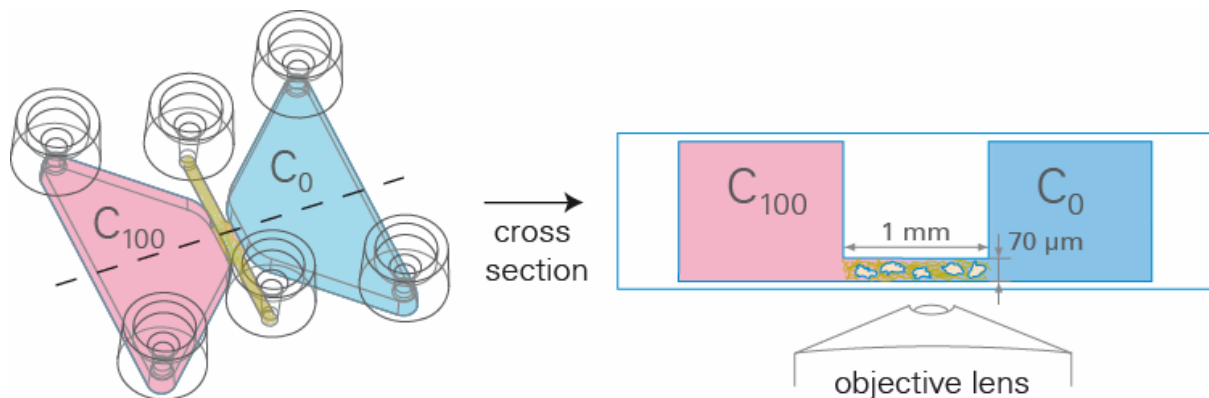

2.2 2D Chemotaxis Experiments Without Gel

It is also possible to conduct 2D experiments without the use of gel. For this method, cells need to be slightly adherent to the surface of the observation area. For 2D chemotaxis experiments, the slow method of chemoattractant filling is necessary, and described in detail in Section 5.2.2 (on page 7).

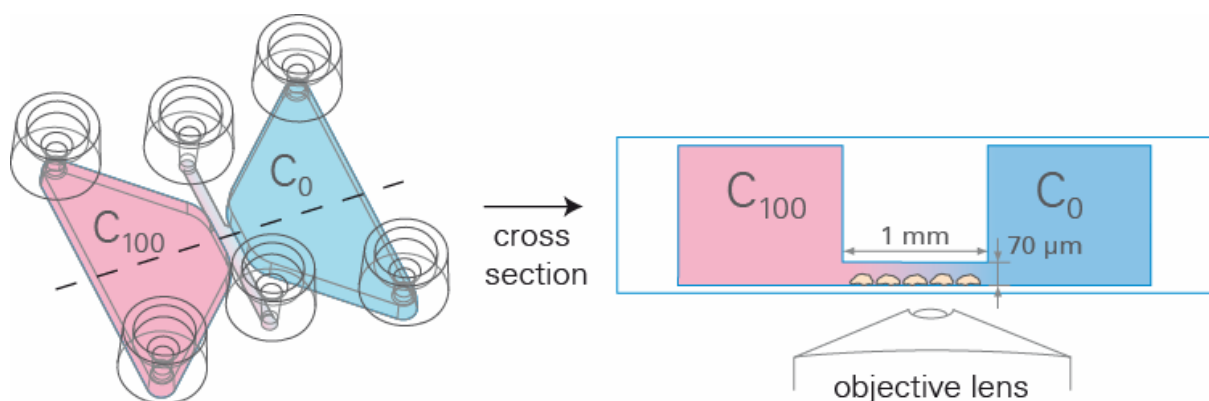

Application Note 17

3 Equipment

When conducting chemotaxis experiments with the μ -Slide Chemotaxis ^{3D}, it is 100% necessary to use the following materials and equipment:

- Cells and a gel matrix suitable for the cells
 - See [Application Note 23](#) for an example protocol for chemotaxis of dendritic cells.
 - See [Application Note 26](#) for Collagen I gels with different concentrations and media.
- A humid chamber, such as a 10 cm Petri dish with wet tissue (as shown on the right)
- Optimal conditions for the cells (at the heated or incubated stage)
- An inverted microscope (e.g., phase contrast or fluorescence)
- Time lapse video equipment: CCD camera, video camera, and acquisition software
- Use only the correct 10 - 200 μ l pipet tips (others do not work).
 - Greiner Bio-One 739261, 739280, 739290, 772288, or related beveled Greiner tips
 - Axygen T-200-C, TR-222-C, TR-222-Y, or related Axygen beveled tips
 - STARLAB TipOne RPT S1161-1800, or related beveled TipOne tips
 - Sorenson BioScience MulTi Fit Tip 10590, 15320, 15330
- Slant cosmetics tweezers, for plug handling
- Optional: Motorized stage and autofocus (x,y,z), to observe all 3 chambers, in parallel

4 Surfaces and Coatings

4.1 ibiTreat (80326)

The ibiTreat (hydrophilic) surface facilitates the filling of the structure, with aqueous gels for 3D assays.

4.2 Collagen IV Surface Coated (80322)

The Collagen IV pre-coated slides do not contain a collagen gel. Only the surface is coated with Collagen IV to mediate cell adhesion for 2D chemotaxis experiments.

Other surface coatings can be made by following [Application Note 08](#):
http://www.ibidi.de/service/application_notes/AN08_Coating.pdf

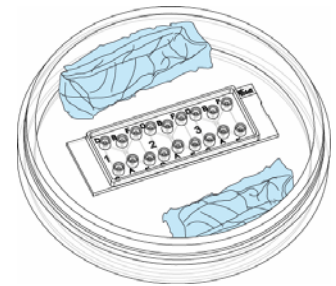

Humid Chamber
With wet sterile tissue.



Beveled Pipet Tip
See list for correct models

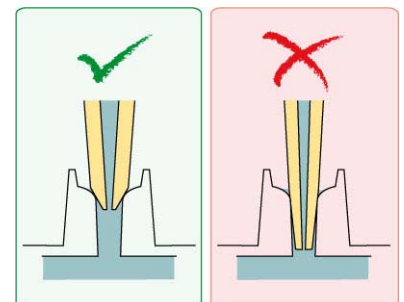

Correct Tip

- Fits on top
- Closes completely
- Does not get stuck

Incorrect Tip

- Fits too tightly
- Gets stuck



Slant Tweezers
For convenient plug handling

5 3D Experiment with Cells in Gel

5.1 Seeding Cells in Gel

- 1) Unpack the μ -Slide Chemotaxis and put it into a 10 cm Petri dish with a sterile, wet tissue around the slide. This helps to decrease the evaporation.
- 2) Prepare cell suspension, as usual.
- 3) Prepare gel matrix. Sample gel protocols are given in Application Notes 23 (Chemotaxis of Dendritic Cells) and 26 (Collagen I Protocols).
- 4) Mix the cell suspension and gel to a final cell concentration of ca. 3×10^6 cells/ml. High cell concentrations are needed, due to the small height of the observation area.
- 5) Close Filling Ports C, D, E, and F with the plugs. Handle the plugs with the appropriate blunt tweezers.
- 6) Use a 20 μ l pipet (e.g., Gilson P-20) and apply 6 μ l of gel mixture to the top of Filling Port A, leaving space between the tip and the port. Do not inject the gel directly.
- 7) Immediately afterwards, use the same pipet settings (6 μ l) and aspirate air from the opposite Filling Port B. Press the pipet tip directly into the port. The liquid gel from Filling Port A will be flushed inside, filling the entire channel homogeneously. Aspirate until the liquid gel reaches the pipet tip.
- 8) Leave both Filling Ports A and B filled with gel. Level out the liquid heights in both filling ports, as shown in the cross section.
- 9) Gently remove all plugs from Filling Ports C, D, E, and F. Close Filling Ports A and B with plugs.
- 10) Incubate the slide inside a sterile and humid atmosphere to minimize evaporation until the gel is formed. To make sure evaporation is low, use a sterile 10 cm Petri dish with an extra wet tissue around the slide (see Humidity Chamber, on page 4).
- 11) Control the cell morphology with a microscope during and after gelation (see the Note: Cell Morphology, on page 17). Check the amount of gel in the channel and Filling Ports A and B to control the evaporation.

The day before seeding the cells and conducting the experiment, it is necessary to place all cell media, the μ -Slide, and plugs into the incubator for gas equilibration. The medium should be put into a slightly opened vial. This will prevent the medium inside the slide, and the slide itself, from allowing air bubbles to form during the incubation time.

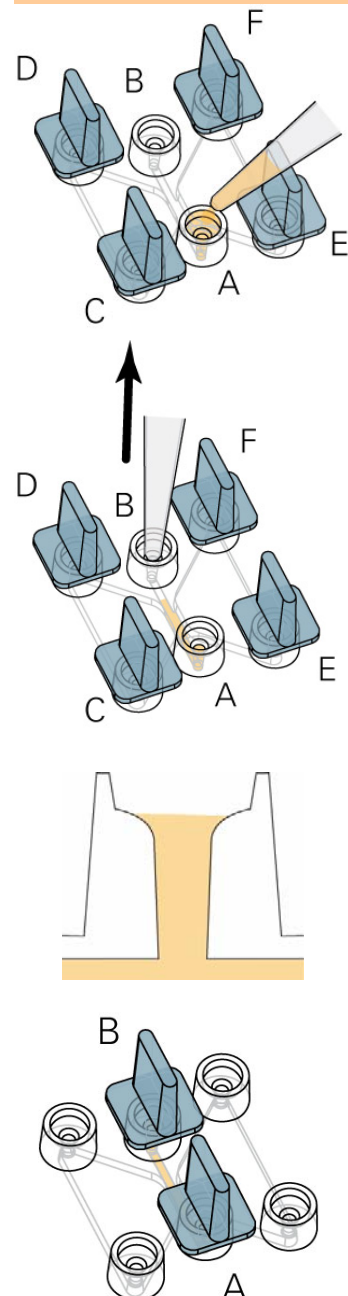

Application Note 17

5.2 Filling the Reservoirs

5.2.1 Fast Method

With this procedure, one large reservoir is completely filled with chemoattractant. The downside of this method is that sensitive cells may initially be saturated by chemoattractant.

To use this method, follow these steps:

- 1) Gently close Filling Ports C and D with plugs (chemoattractant side).
- 2) Fill the first reservoir by injecting chemoattractant-free medium through Filling Port E. Use 65 μl and the recommended pipet tips. Keep in mind that Filling Ports E and F must be completely filled, but not overfilled.
- 3) Transfer the two plugs from Filling Ports C and D to Filling Ports E and F. This will close the chemoattractant-free side.
- 4) Inject 65 μl of chemoattractant into Filling Port C, as shown. Do not trap air bubbles. Note: The chamber is now completely filled and cells are only kept inside the gel in the observation area.
- 5) Close the Filling Ports C and D with plugs (chemoattractant side).
- 6) Control your cells under the phase contrast microscope. Note: The chemoattractant will immediately diffuse through the observation area and establish a linear concentration profile over the cells.

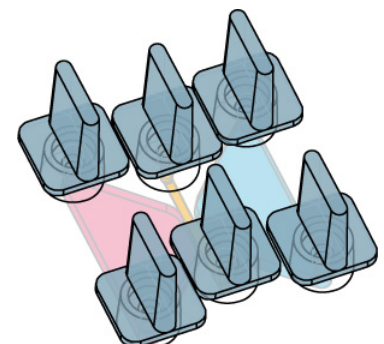
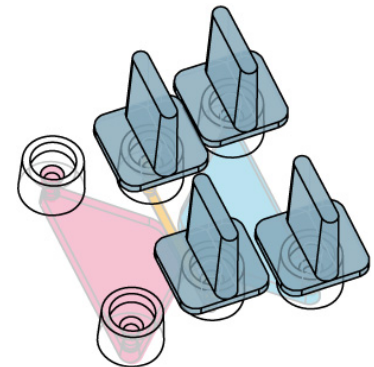
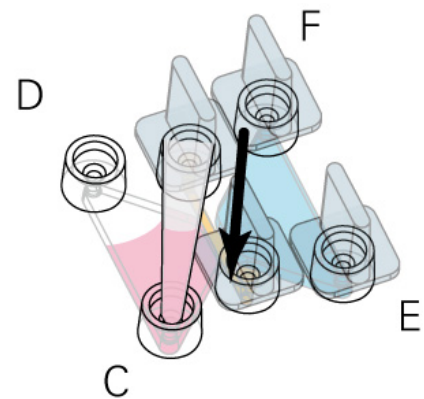
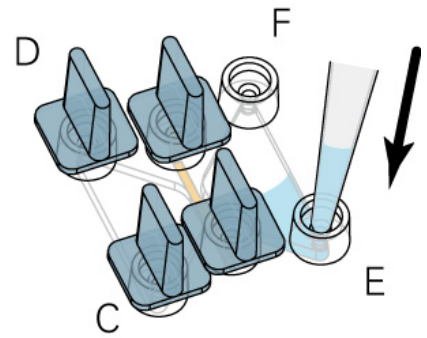

Application Note 17

5.2.2 Slow Method

This procedure is similar to the chemoattractant filling in μ -Slide Chemotaxis 2D. Both large reservoirs are first filled with neutral solution. Next, the chemoattractant is applied without directly reaching the observation area.

As a result, there is a short delay in gradient formation and sensitive cells cannot be initially saturated. The resulting concentration in the reservoir is 0.5 times the injected concentration, because 30 μ l chemoattractant is diluted with 30 μ l of neutral solution.

To use this method, follow these steps:

- 1) Gently close Filling Ports C and D with plugs (chemoattractant side).
- 2) Fill the first reservoir by injecting chemoattractant-free medium through Filling Port E. Use 65 μ l and the recommended pipet tips. Keep in mind that Filling Ports E and F must be completely filled, but not overfilled.
- 3) Transfer the two plugs from the Filling Ports C and D to the Filling Ports E and F. This will close the chemoattractant-free side.
- 4) Fill the empty reservoir by injecting chemoattractant-free medium through Filling Port C. Use 65 μ l and the recommended pipet tips.
- 5) Now the chamber is completely filled with chemoattractant-free medium and cells will only grow inside the gel in the observation area. Control your cells under the phase contrast microscope.
- 6) Use a 20 μ l pipet (e.g. Gilson P-20) and apply 15 μ l chemoattractant to the top of Filling Port C, as shown. Do not inject directly.
- 7) Use the same pipet settings and aspirate 15 μ l air from the opposite Filling Port D. Press the pipet tip directly into Filling Port D. The chemoattractant on top of Filling Port C will be flushed inside and fill the reservoir.

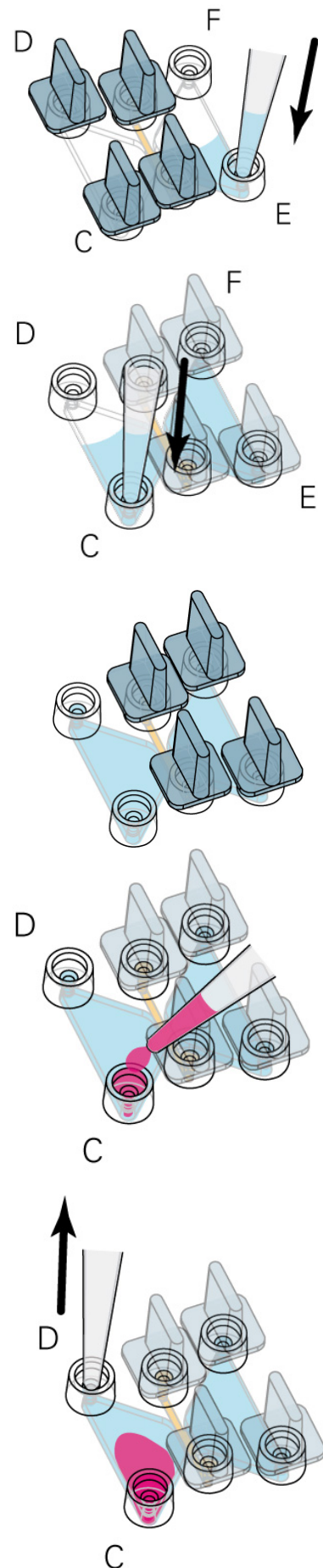

Application Note 17

- 8) Repeat this step once, in order to fill 30 μl inside the reservoir.
- 9) The resulting concentration in the reservoir is 0.5 times the injected concentration, because 30 μl of chemoattractant is diluted with 30 μl of neutral solution.

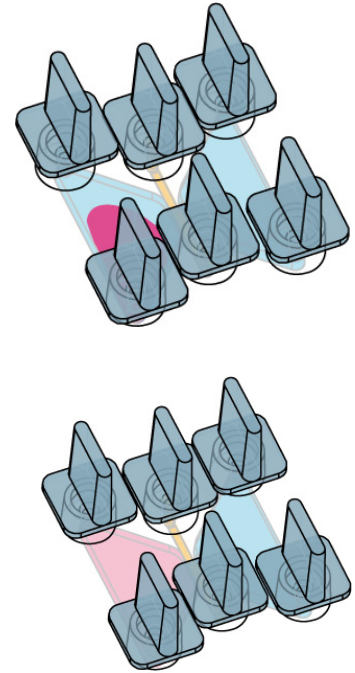

6 2D Experiment with Cells on a 2D Surface

6.1 Seeding Cells

- 1) Unpack the μ -Slide Chemotaxis ^{3D} and put it into a 10 cm Petri dish with a sterile, wet tissue around the slide to decrease evaporation.
- 2) Prepare your cell suspension, as usual. Use a cell suspension of approx. 3×10^6 cells/ml. High cell concentrations are needed due to the small height of the observation area.
- 3) Close Filling Ports C, D, E, and F with plugs. Handle plugs with the appropriate slant tweezers.
- 4) Use a 20 μl pipet (e.g. Gilson P-20) and apply 6 μl cell suspension onto Filling Port A. Do not inject directly.
- 5) Immediately afterwards, use the same pipet settings (6 μl) and aspirate air from the opposite Filling Port B. Press the pipet tip directly into the port. The liquid from Filling Port A will be flushed inside, filling the entire channel homogeneously. Aspirate until the cell suspension reaches the pipet tip. Leave both Filling Ports A and B filled with liquid. Level out the liquid heights in both filling ports, as shown.

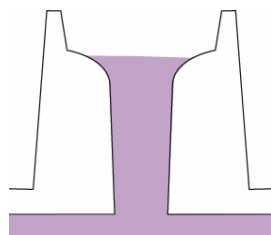

The day before seeding the cells and conducting the experiment, it is necessary to place all cell media, the μ -Slide, and plugs into the incubator for gas equilibration. The medium should be put into a slightly opened vial. This will prevent the medium inside the slide, and the slide itself, from allowing air bubbles to form during the incubation time.

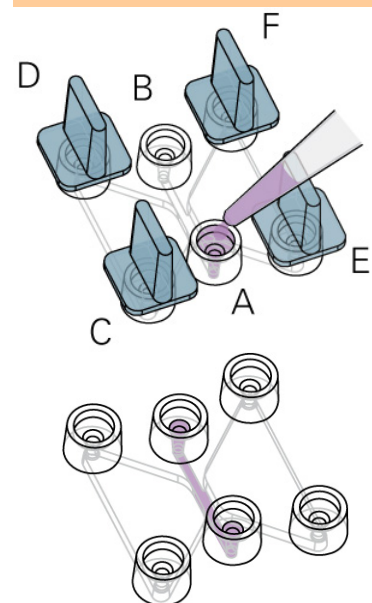

Application Note 17

- 6) Gently remove all plugs from Filling Ports C, D, E, and F. Close the slide with the cultivation lid.
- 7) Incubate the slide inside a sterile and humid atmosphere to minimize evaporation until the cells have attached. Make sure evaporation is low by using a sterile 10 cm Petri dish with an additional wet tissue placed around the slide.

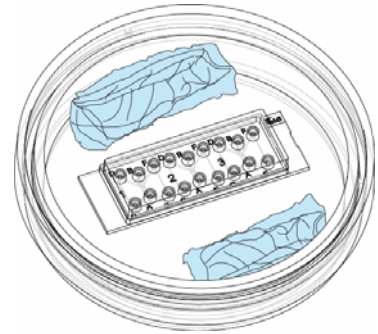

6.2 Cell Attachment

During and after cell attachment, control cell morphology with a microscope. To control evaporation, check the amount of liquid in the channel and Filling Ports A and B.

After cell attachment (1 to 5 hours), the removal of the non-adherent cells and seeding medium is recommended. (Skip this step when you are working with cells that are only slightly adherent.)

Follow these steps:

- 1) Gently close Filling Ports C, D, E, and F with plugs (not shown).
- 2) Fill 10 μl of cell-free medium into Filling Port A. Do not trap any air bubbles.
- 3) Aspirate the same amount of liquid (10 μl) from Filling Port B, as shown.
- 4) Repeat Step 3 twice.
- 5) Leave both of the Filling Ports A and B filled with liquid and level out the liquid heights in both.
- 6) Gently remove all plugs from Filling Ports C, D, E, and F. Close Filling Ports A and B with plugs.

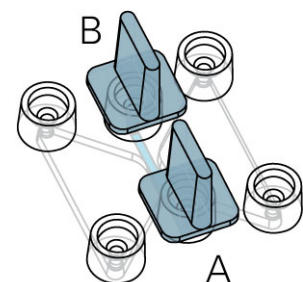
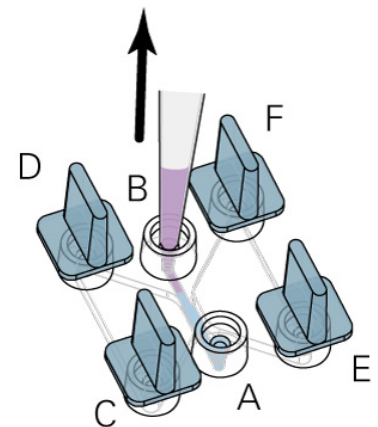
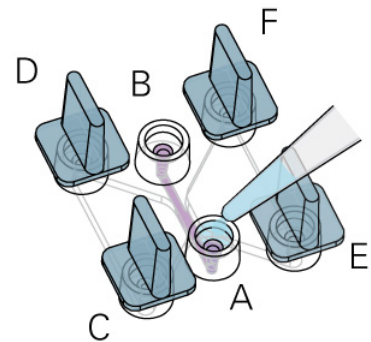

Application Note 17

6.3 Filling the Reservoirs

- 1) Gently close Filling Ports C and D with plugs (chemoattractant side).
- 2) Fill the first reservoir by injecting a chemoattractant-free medium through Filling Port E. Use 65 μl and the recommended pipet tips. Keep in mind that the Filling Ports E and F must be completely filled, but not overfilled.
- 3) Transfer the two plugs from the Filling Ports C and D to Filling Ports E and F to close the chemoattractant-free side.
- 4) Fill the empty reservoir by injecting chemoattractant-free medium through Filling Port C. Use 65 μl .
- 5) Now the chamber is completely filled with chemoattractant-free medium and cells grow only in the observation area. Control your cells under the phase contrast microscope.
- 6) To apply a chemoattractant, use a 20 μl pipet (e.g. Gilson P-20) and apply 15 μl chemoattractant on top of Filling Port C, as shown. Do not inject directly.
- 7) Use the same pipet settings and aspirate 15 μl air from the opposite Filling Port D. Press the pipet tip directly into Filling Port D. The chemoattractant on top of Filling Port C will be flushed inside and fill the reservoir.
- 8) Repeat this step once, in order to fill 30 μl inside the reservoir.
- 9) The resulting concentration in the reservoir is 0.5 times the injected concentration, because 30 μl of chemoattractant is diluted with 30 μl of neutral solution.

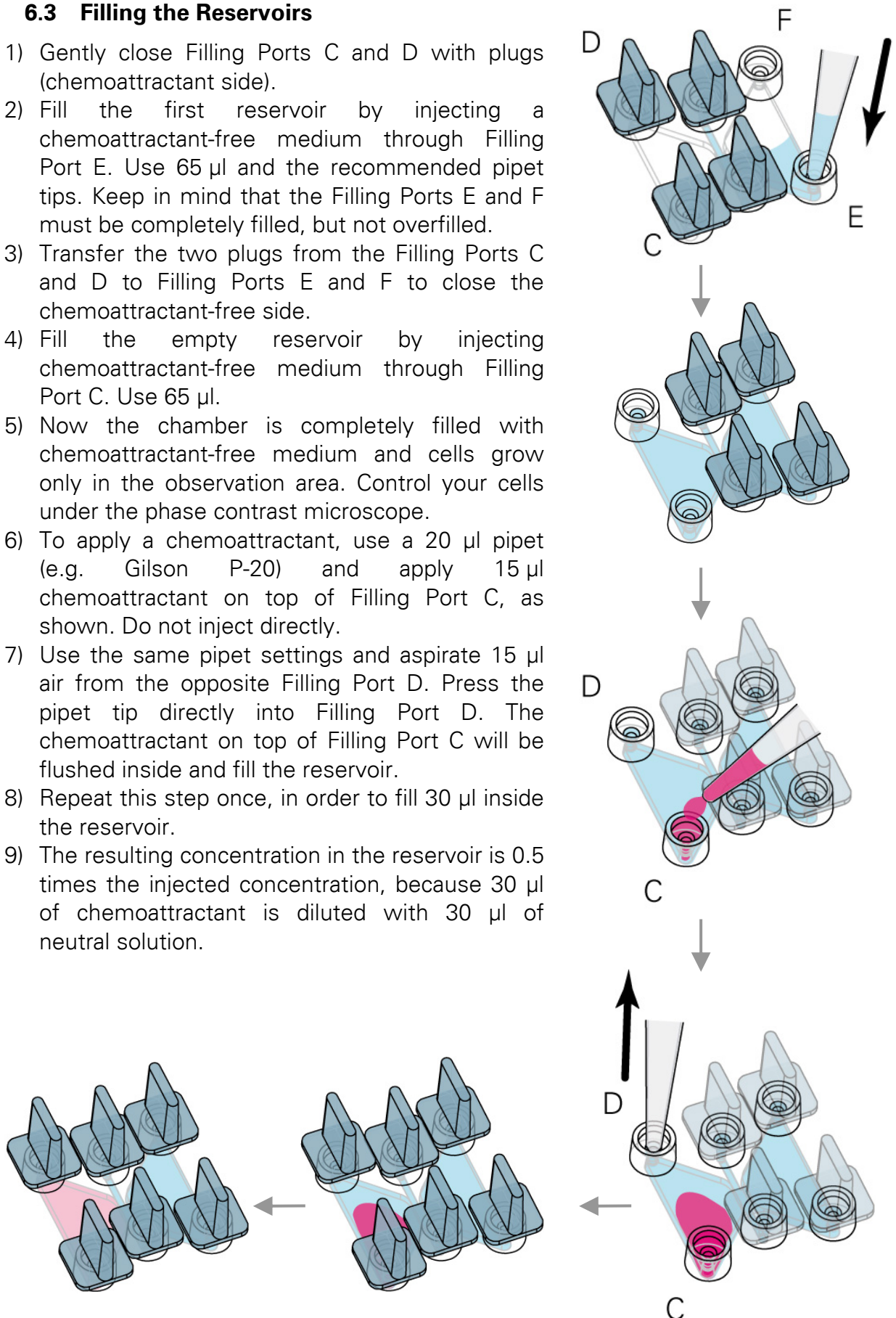

7 Video Microscopy

Video microscopy is a necessary tool for ibidi's μ -Slide Chemotaxis^{3D}. Without it, there is no access to the analysis of the chemotaxis and migration effects.

- 1) Mount the μ -Slide on the stage of your inverted and incubated microscope, then observe cell movement within the observation areas. Depending on the cells' velocity, one frame per every 1-10 minutes should be sufficient. For optimal migration data of migrating cells, we recommend starting the experiment immediately after injecting the attractant. Observe cell movement over a few hours. After the initial experiments, the time can be changed for a more efficient use of experimental time.
- 2) Depending on your cells' requirements, the use of heating and incubation devices may be necessary. Please contact us for more details on incubation systems that work with your current microscope.
- 3) After mounting the slide on the microscope stage, wait 20 minutes for temperature equilibration.
- 4) Start a time-lapse experiment with a 5x or 10x objective. Higher magnifications are possible but for optimal migration data it is necessary to track at least 20 – 40 cells.
- 5) After the time-lapse, export your images as single files.

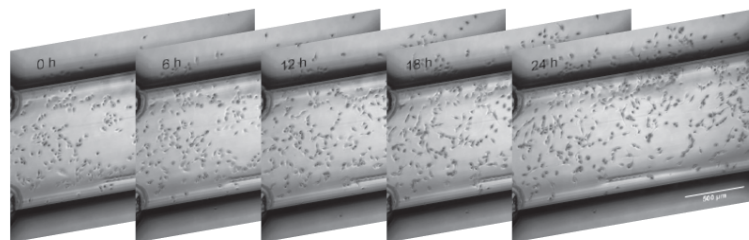

Depending on your focus of interest, choose a magnification:

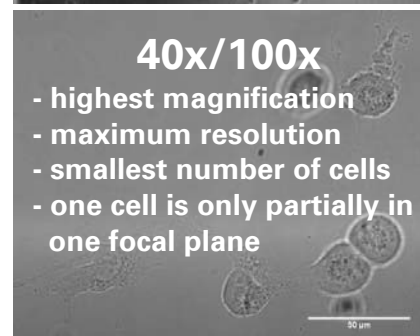
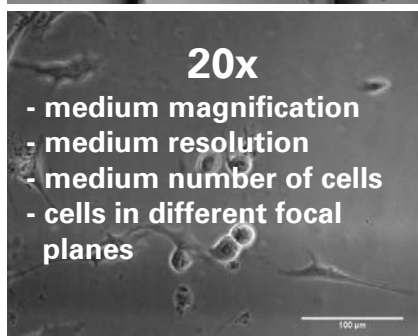
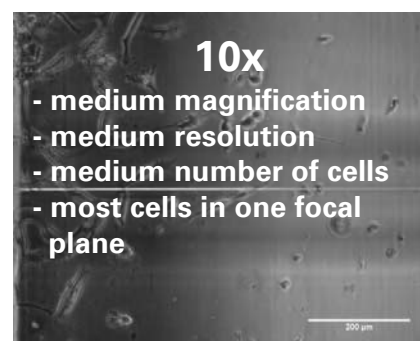
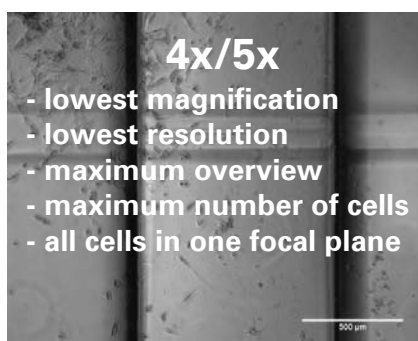

8 Chemoattractant Concentrations and Recommended Experimental Setups

For optimal results, we recommend performing two control experiments by filling the chamber completely with, or without, chemoattractant solution. This helps determine if a compound is influencing the directed movement of cells (chemotaxis) and/or is influencing random migration (chemokinesis).

C₁₀₀ Concentration in stable gradient equilibrium (= max. concentration reaching the cells on one edge of the observation area).

C₀ Solution without (or with a low concentration) of chemoattractant.

For the +/+ control experiment, remember to also prepare the gel with the chemoattractant solution C₁₀₀.

When following the filling method from Section 5.2.2 and 6.3, the chemoattractant is diluted to half of its concentration (30 µl + 30 µl).

Recommended setup for one slide:

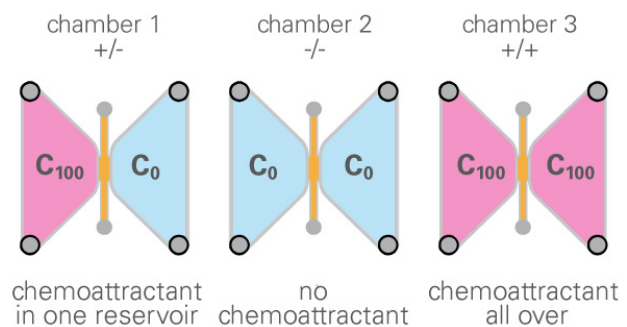

9 Tracking Cells as a 2D Projection

When cells migrate through a 3D matrix, we recommend tracking them as a projection into the x,y plane. This simplifies analysis, and is considered to be correct in a channel with an aspect ratio of 10:1 (length:height), or bigger.

After the experiment, it is necessary to track the cells with the appropriate software. We recommend, for example, the ImageJ plugin, Manual Tracking. This plugin is able to quantify the movement of objects between frames of a temporal stack (see Note: Cell Tracking, on page 17).

- ImageJ is available here: <http://rsb.info.nih.gov/ij/>
- The Manual Tracking plug-in (including a PDF documentation) by Fabrice Cordelières, Institut Curie, Orsay, France is available here: <http://rsbweb.nih.gov/ij/plugins/track/track.html>
- Download Manual_Tracking.class into the plugins folder of ImageJ on your computer and restart ImageJ. Make sure you have administrator rights.

Here is a quick guide for tracking with Manual Tracking:

- 1) Import a movie as single page .tif files, by using „File/Import/Image_Sequence”.
- 2) Open plugin “Manual Tracking”.
- 3) Select “Add track”.
- 4) Follow the first cell, through all of the time points, by clicking on the cell’s midpoint.

Application Note 17

After the first click, the software creates the results table in an extra window. This table is filled with the x/y data of each cell, at each time point.

- 5) Save the data table after tracking is completed.
- 6) The data table contains all tracked cells (=tracks) and time points (=slices) with (x,y) positions.

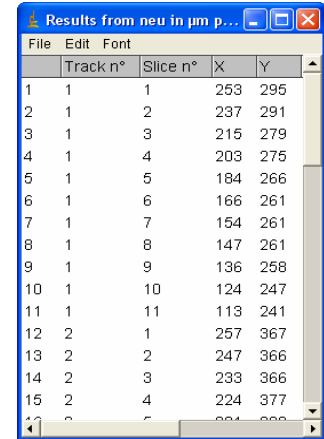

	Track n°	Slice n°	X	Y
1	1	1	253	295
2	1	2	237	291
3	1	3	215	279
4	1	4	203	275
5	1	5	184	266
6	1	6	166	261
7	1	7	154	261
8	1	8	147	261
9	1	9	136	258
10	1	10	124	247
11	1	11	113	241
12	2	1	257	367
13	2	2	247	366
14	2	3	233	366
15	2	4	224	377

- For tracking, we recommend printing out the first image of each image stack before the movie is watched for the first time. At least 40 cells are uniformly marked in order to 1) ensure homogeneity and 2) avoid tracking the same cell twice. At least 30 cells in the observation field need to be tracked during the entire experiment. Some cells will be lost through cell death, cell division, and cells leaving the observation field. We do not recommend using such cells for data analysis.
- You can also export "Overlay Dots & Lines" as a movie file (.avi).

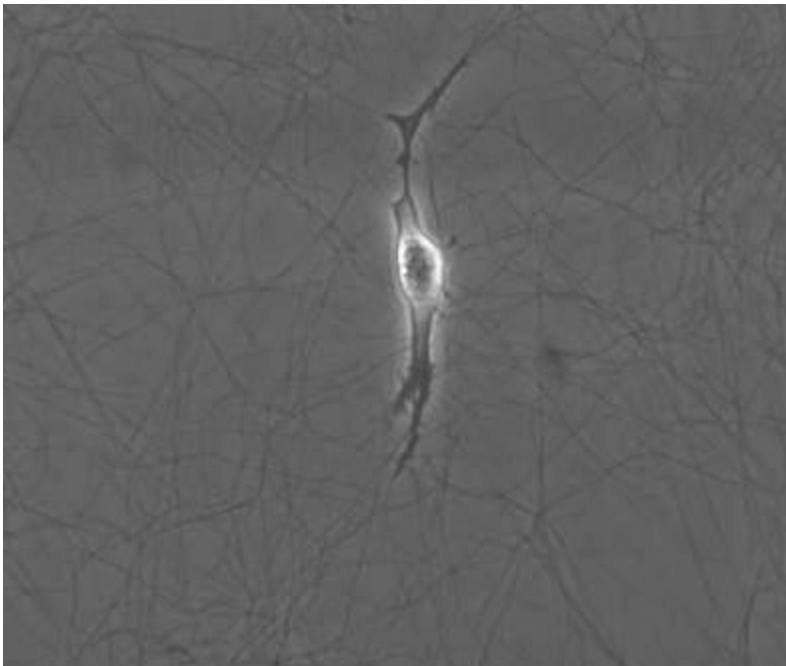

HT-1080 fibrosarcoma cell migrating inside a Collagen I gel.

Application Note 17

10 Analyzing Chemotaxis

ibidi provides a free software tool for plotting and analyzing the tracked data. For a copy, go to: http://www.ibidi.de/applications/ap_chemo.html

Here is a quick guide for data analysis:

- 1) Import the data table from "Manual Tracking" (tab-separated .xls file)
- 2) Select the number of slices (=number of pictures used for tracking). The number of slices can be found in your original data table ("Show original data").
- 3) Calibrate the software by setting the x/y calibration and the time interval. x/y calibration is the length of one pixel in μm .
- 4) Press "Apply settings", after changing values and parameters.
- 5) Create trajectory plot, and then export as an image.
- 6) Export values of center of mass, FMI, and Rayleigh test.
- 7) Calculate a two-tailed unpaired Student t-test with independent variances for the single values from 6). Compare the chemotaxis experiment +/- and the two control experiments -/- and +/+ with each other to show statistical significance.

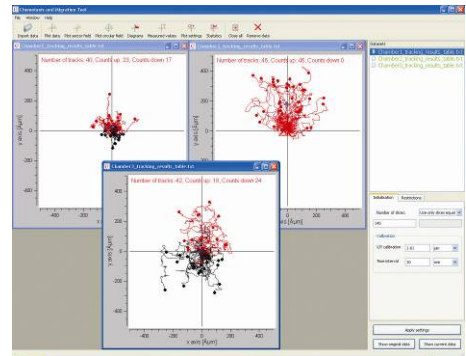

Example: Use the following command in Microsoft Excel.

=TTEST(A2:A4;B2:B4;2;3)

Here are some recommendations for presenting the results (in talks or publications):

- Show the original movie (time lapse film of your cells).
- Play the trajectory movie (time lapse film + overlaid cell trajectories).
- Display the trajectory plot (graph).
- Show the table or bar graph of center of mass, FMI, and Rayleigh test.
- Include the results of the Student's t-test.

11 Tips, Tricks, and Troubleshooting

11.1 Avoiding Air Bubbles

Air bubbles are 1) emerging over time due to non-equilibrated media and slides, or 2) injected, or brought into the chamber, by the user. Both types will disturb the diffusion-driven concentration gradient with convection and must be avoided.

- Air bubbles that emerge over time can be avoided by equilibrating all media and equipment inside the incubator overnight. Medium is put into a slightly opened vial. Slides and plugs can be left in the sterile packaging.
- Air bubbles introduced to the chamber by injection, or by the user, can be avoided by correct handling. Please watch out for unfilled filling ports and trapped air bubbles inside the pipet tip! Keep in mind that an air bubble might be trapped when closing an empty filling port with a plug. Always make sure the filling ports are completely filled, but not overfilled.

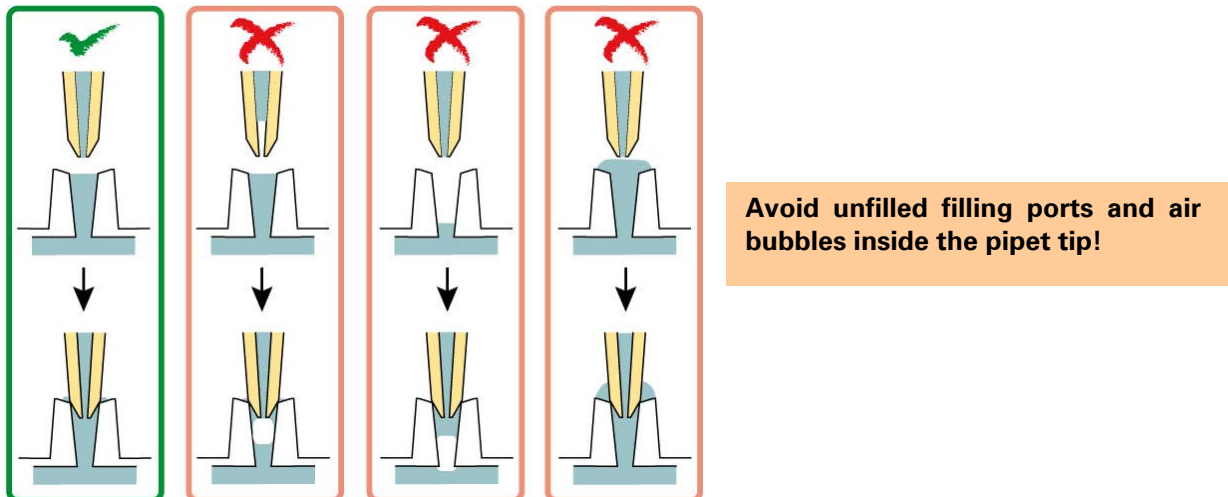

Filling ports that are accidentally emptied, or left empty, can be refilled with a 10 μ l pipet that has a very thin pipet tip. Note: Never use the standard-sized pipet tips for this procedure, but use the next smallest size. An air bubble might be trapped.

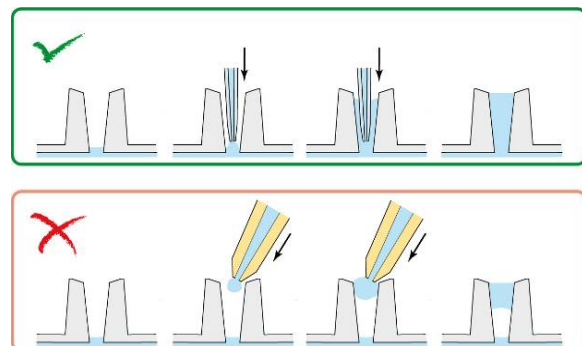

Application Note 17

11.2 Focus Not Stable

Focus drift is an annoying effect, especially during time lapse experiments. Focus stability is negatively affected by mechanical changes and temperature instabilities.

Follow these recommendations to keep your cells in focus:

- Switch on all components (heating, gas incubation, computer, other equipment) at least 60 minutes before starting the time-lapse recording.
- After you put the μ -Slide onto the microscope, wait 20 minutes before starting a time lapse experiment to achieve temperature (and immersion oil) equilibration.
- Keep the room temperature as stable as possible. Air conditioning should either be working continuously or switched off completely.
- Do not change temperature during experiments. Avoid being near door and window openings, as this could rapidly change the temperature.
- Eliminate all sources of mechanical vibrations. Use a damped table for your microscope.
- Use an autofocus system.

11.3 Chamber Not Filling Properly

Here are some general tips and tricks for filling the chamber:

- During the filling of liquid by injection, incline the slide in a way that the liquid is beneath air. By doing this, air can escape through the filling ports.
- Always use chambers that are completely dry, especially after coating the chambers. Small amounts of remaining liquid might hinder proper handling.
- Use a pipet that is serviced routinely. After a few years of use, pipets can lose pressure during pipetting. In normal work they might perform well, but there can be problems when they are used with μ -Slide Chemotaxis^{3D}.

11.4 Cells Die in the Gel Matrix

pH and salt concentrations can cause many problems in gel matrices. Please test any gel protocol with your cells in an environment suited for this purpose. We recommend small open wells, such as μ -Slide Angiogenesis, where the cells can be seeded in a larger volume.

11.5 Cells Do Not Migrate in Gel

To help find a solution, here are some questions to ask:

- *Are the cells seeded in an optimal growth medium?*
- *Is the pH in an optimal range for the cells?*
- *Can the cells degrade the gel matrix?*
- *Is the concentration of gel too high? Is the gel too stiff?*
- *Are there suitable binding motifs for cell attachment?*

Application Note 17

11.6 Cells Do Not Attach Properly (2D Assay Only)

The chamber's geometry is very specialized. The cell seeding step is especially critical, because the volume is very low. Most problems with cell attachment can be avoided by checking these following facts:

- *Are the cells seeded in optimal growth medium?*
Adherent cells will not attach properly when they are seeded in a starvation medium. Use normal growth medium with all the necessary supplements.
- *Is the slide put into an extra humid chamber?*
Evaporation is one of the most crucial issues during cell attachment. Make sure to provide a maximum of humidity during cell attachment. Use a 10 cm Petri dish with wet tissue.
- *Is the incubator frequently opened during the cell attachment phase?*
Frequent door openings must be avoided because this drastically lowers humidity inside the incubator for a time. Use a cell culture incubator that is not being used by others during cell attachment.

11.7 Inhomogeneous Cell Distribution (2D Assay Only)

Inhomogeneous cell distribution, and especially high cell densities close to the observation area, negatively overlay directed migration and must be avoided. Carefully conduct all of the steps in this Application Note to avoid spilling cell suspension into the reservoirs. Never inject cell suspension directly into the filling ports.

12 Notes

12.1 Note: Gel Filling

Gel mixture is filled in a faster way when directly injected into the channel. After injecting a small amount of gel, the channel is filled. Afterwards, it is necessary to suck out the medium from the opposite filling port, until both ports are equally filled. This procedure needs to be done with extreme caution to avoid spilling any gel mixture into the large reservoirs. When done correctly, this method doesn't need plugs to fill the gel inside the chamber.

12.2 Note: Cell Morphology

Cells should be completely surrounded by 3D gel. Adherent cells might sink down and attach to the 2D surface with time, due to durotaxis. Please make sure to clearly distinguish between cells adhered to surfaces (typically spread out), and cells which are in 3D (typically spherical or spindle-like).

12.3 Note: Cell Tracking

Tracking cells can also be done with different software programs or algorithms.

For more information, please contact info@ibidi.com.